

*Certified*  
**EXPLOSION  
PROOF**

Certified by ETL to meet UL standards for Class I, Div 1 and 2, Group D and Class II, Div 1 and 2, Group F & G.



# FRV 110

**EXPLOSION PROOF SERIES**

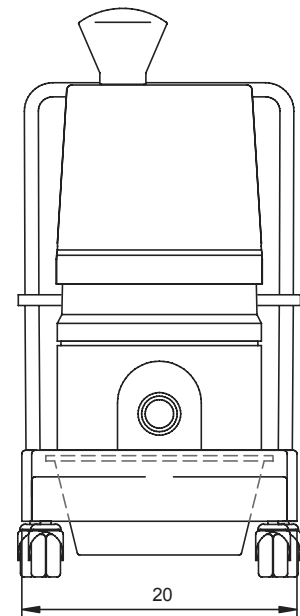
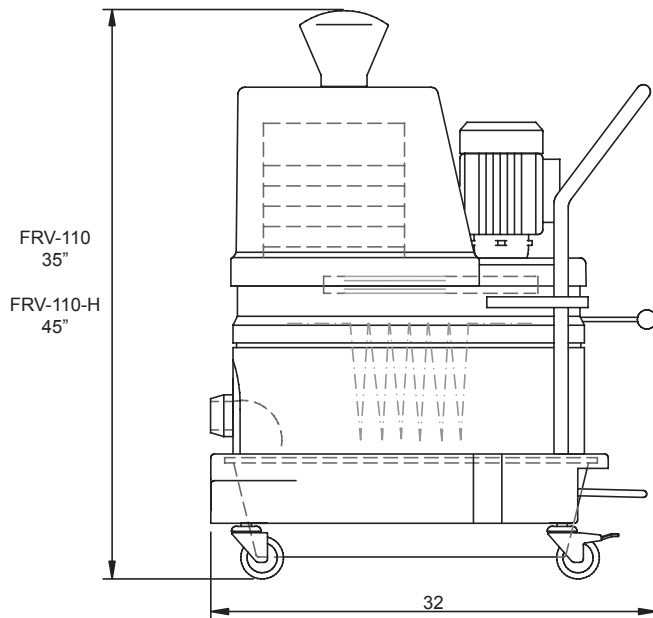

## FRV 110 Standard Specifications

- DS1-EX1000 NRTL CERTIFIED EXPLOSION PROOF Motor & Switch, Class I, Class II
- 1.5 HP Motor, 110 Volt, 16 Amp, Single Phase, 60 Hz
- 13 ft<sup>2</sup> MicroClean BVSC Filter, Manual Shaker System
- 40 ft<sup>2</sup> HEPA Filter with Minihelic (optional)
- 2" (50mm) Inlet Connection with Bronze Cast Deflector
- Multi-Stage Centrifugal High Performance Turbine w/Relief Valve
- 9 Gallon, Foot Lever Actuated Dustpan
- Counterbalanced Base with 3" Heavy Duty Conductive Casters
- Compression Cast Composite Modular Housing
- Carbon Impregnated, Anti-Static 10<sup>-6</sup> Ohms
- DEX Accessory Package 151510DEX: Vacuum Hose: 1.5" x 10', Urethane, Static Conductive., Molded Carbon Impregnated Cuffs; Wand: 54", Aluminum Shaft, 2 Bends; Crevice Tool: 11", Aluminum Body; Round Brush: 3", Nylon Bristles, Static Conductive, Carbon Impregnated; Floor Brush: 14", Metal Body, Anti-Static Bristles; Reducer: 2" x 1.5"



**Base Price: FRV 110 - \$6,310.50**

ADDER	DESCRIPTION	PRICE
35193	Explosion Proof HEPA Module	\$1,050.00
24000	Static Conductive Disposable Dustpan Liner with Lid	\$39.50
1560OHDEX	Overhead Cleaning Accessory Kit	\$425.00
-25	Optional - increase hose length to 25'	\$250.00
L-EX	Extended Caster Frame Assembly w/ Antistatic Casters	\$825.00